

AKO-17632 **AKO-17633** **AKO-17634** **AKO-17635**
AKO-17636 **AKO-17637** **AKO-17520** **AKO-17521**

PROCool Electronic Panel

User manual



AKO

Index	Page
1.- Presentation	3
1.1.- Maintenance	3
1.2.- Precautions	3
2.- Versions and references	3
3.- Recommendations	4
4.- Description	5
4.1.- Key function	5
4.2.- Messages	6
5.- Component location	7
6.- Quick configuration	9
7.- Operation	10
7.1.- Compressor control	10
7.2.- Defrost control	12
7.3.- Fan control	13
7.4.- Condenser fan control	13
7.5.- Pump down function	14
7.6.- Alarms	15
7.7.- Access code (password)	16
8.- Parameter transfer	17
9.- Advanced configuration	18
9.1.- Return to initial parameters	18
9.2.- Program version	18
9.3.- Parameters	19
10.- Technical specifications	23

AKO Electromecànica thanks you and congratulates you on the purchase of our product, the development and manufacture of which involved the most innovative technologies, as well as rigorous production and quality control processes.

Our commitment to achieving customer satisfaction and our continuous efforts to improve day by day are confirmed by the various quality certificates obtained.

This is a high performance, technologically advanced product. Its operation and the final performance achieved will depend, to a great extent, on correct planning, installation, configuration and commissioning. Please read this manual carefully before proceeding to install it and respect the instructions in the manual at all times.

Only qualified personnel may install the product or carry out technical support.

This product has been developed for use in the applications described in the manual. AKO Electromecànica does not guarantee its operation in any use not foreseen in this document and accepts no liability in the case of damage of any type which may result from incorrect use, configuration, installation or commissioning.

Complying with and enforcing the regulations applying to installations where our products are destined to be used is the responsibility of the installer and the customer. AKO Electromecànica accepts no liability for damage which may occur due to failure to comply with these regulations. Rigorously follow the instructions described in this manual.

In order to extend the lifetime of our products to the maximum, the following points must be observed:

Do not expose electronic equipment to dust, dirt, water, rain, moisture, high temperatures, chemical agents or corrosive substances of any type.

Do not subject equipment to knocks or vibrations or attempt to handle them in any way differently to that indicated in the manual.

Do not under any circumstances exceed the specifications and limitations indicated in the manual.

Respect the indicated environmental conditions for operation and storage at all times.

During installation and on completion of this, avoid the presence of loose, broken or unprotected cables or cables in poor condition. These may constitute a risk for the equipment and its users.

AKO Electromecànica reserves the right to make any modification to the documentation and the product without prior notification.

1.- Presentation

PROCool is the comprehensive electronic solution for managing both positive and negative refrigerated facilities.

- Rapid start-up thanks to its quick programming menu.
- Large format display for better viewing.
- Hot keys for the most frequently used functions.

It has a high level of IP65 protection for installation in humid environments.

1.1.- Maintenance

Clean the surface of the unit with a soft cloth, water and detergent. Do not use abrasive detergents, petrol, white spirits or solvents.

1.2.- Precautions

Using the equipment without following the manufacturer's instructions may affect the device's safety requirements. To ensure that the device operates correctly, only probes supplied by AKO should be used.

Between -40 °C and +20 °C, if the NTC probe is extended up to 1,000 m with minimum 0.5 mm² wire, the maximum deviation will be 0.25 °C (Wire for probe extension ref. **AKO-15586**)



IMPORTANT:

- The function of the digital inputs depends on the configuration (See page 22).
- The recommended currents and powers are the maximum working currents and powers.

2.- Versions and references

	Compressor	Condenser fans		Evaporator fan		Defrost resistances		Power supply	I Max. *
		230 V-I	400 V-III	230 V-I	400 V-III	230 V-I	400 V-III		
AKO-17632	3 - 25 A 400 V-III / 230 V III	2 x 1.6 A	-	4 A	-	-	-	400 V-III / 230 V III 50/60 Hz**	32 A
AKO-17633		-	2 x 3 A	4 A	-	-	-		
AKO-17634		-	2 x 3 A	-	0.3 - 6 A	-	-		
AKO-17635		2 x 1.6 A	-	4 A	-	-	20 A		
AKO-17636		-	2 x 3 A	4 A	-	-	20 A		
AKO-17637		-	2 x 3 A	-	0.3 - 6 A	-	20 A		
AKO-17520	3 - 25 A 230 V-I	2 x 1.6 A	-	4 A	-	-	-	230 V-I 50/60 Hz	32 A
AKO-17521			-	4 A	-	20 A	-		

***Max C:** Maximum current allowed; the aggregated compressor and fan consumption (evaporator + condensers) cannot exceed this value.

** For 230 V III power supply, they must be connected exactly as shown in the installation diagram appearing in the panel.

3.- Recommendations

Disconnect the voltage before carrying out any operations inside the electrical panel. All wiring should be according to current standards and should be carried out by authorised staff. Only carry out the wiring foreseen in the wiring diagrams. Using the electrical panel not observing the manufacturer's instructions may alter the appliance's safety requirements. A tool is needed to remove any fixed part.

Panel installation:

It is advisable to leave a clean safety space without obstacles around the panel.

Do not knock or make sudden movements on the panel.

Carry out the wiring according to the installation manual.

The probes and their cables should **NEVER** be installed in a conduit together with power, control or feeder cables.

The earth terminals that the panels contain are installed to guarantee the continuity of earthing, however, earthing is not carried out by the terminal and should be carried out outside the panel.

The neutral ratings are of the TT type. The IT rating should not be used.

Circuit breakers (protective switches) are of the phase/s + neutral, curve C type, guaranteeing switching and protection against overcurrents.

Close the panel when you are not working on it.

Residual current protection outside the electrical panel according to low voltage electrotechnical regulations.

The panels comply with European Standards EN 61439-1 and EN-61439-2 for the electrical panel and EN-60730 for the control board.

Terminals for copper external conductors.

Checks before starting the panel up:

Power supply voltages and frequencies will be the ones that figure in the "Technical specifications" section.

Check that there are no loose parts or foreign bodies on connections or switchgear.

Check that there is no dust or damp inside the panel.

Check the correct fastening of the switchgear and components.

Check the correct tightening of the screws and power connections.

Check the correct connection of the power conductors.

Check the correct insulation of the outer lines and that they do not mechanically force the inner connections of the panel.

Check that the maximum current of the FK1, FK2 and FK3 motor guards has been set correctly (depending on the model).

Before starting the installation up, we recommend preheating the compressor's housing.

Checks during the panel start-up:

Check that no electric arcs occur.

Check that the relays or contactors do not produce ratios.

Check that there is no overheating in cables, controllers and the rest of the switchgear.

Checks after the first 24 hours of operation:

Check that no overheating occurs.

Retighten screws and power connections.

Periodical preventive maintenance:

The panel should remain closed using its lock.

Retighten the power connections once a year.

Check the wear of the switchgear once a year.

Clean the outer surface of the panel with a soft cloth, water and detergent. Do not use abrasive detergents, petrol, white spirits or solvents.

Technical data:

Working ambient temperature: -5°C to 40°C

Rated isolation voltage $U_i = 440\text{V}\sim$

Electrical panels with degree of protection: IP 65

CEM B environment

Terminals for copper conductors

Resistance to short-circuits $I_{cc}=6\text{ kA}$

Rated pulse voltage (V_{imp}) 2,5 KV

Cable isolation voltage:

Operation: 500V (Halogen free)

Power: 750V (Halogen free)

4.- Description

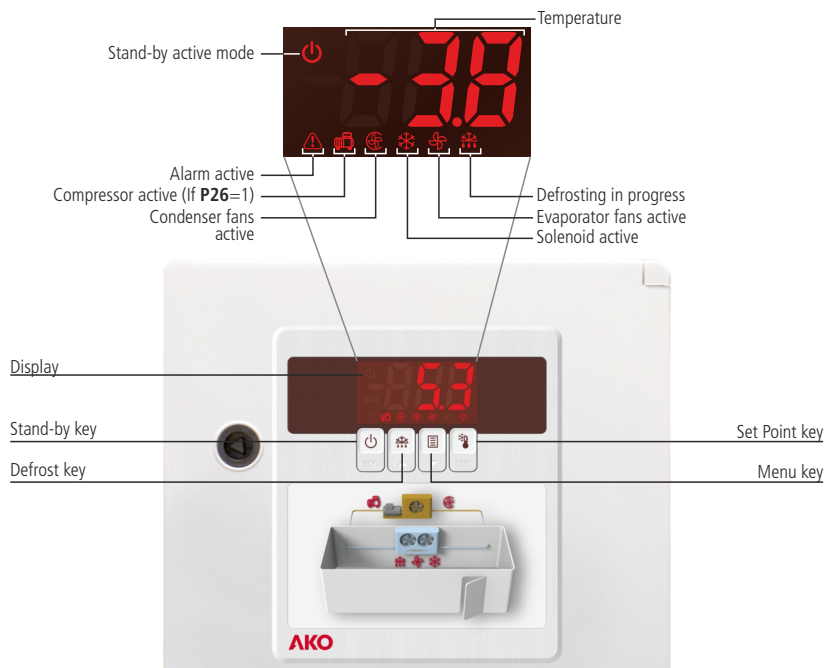

4.1.- Key function



Pressing it for 5 seconds activates the Stand-By mode. Pressing it for 2 seconds the unit returns to the normal mode. In Stand-by mode, the unit performs no action and the display only shows the C indicator along with the temperature.

During configuration, it exits the parameter without saving changes, returns to previous level, or exits programming.



Pressing for 5 seconds accesses the **quick configuration** menu. Pressing for 10 seconds accesses the **advanced configuration** menu.

During configuration, it allows you to scroll through the different levels, or when setting a parameter, to change its value.



One short press* shows the non-displayed probe reading (see **P8** parameter). Pressing it for 5 seconds starts/stops the defrost. During configuration, it allows you to scroll through the different levels, or when setting a parameter, to change its value.



One short press* displays the current set point value (SP). Pressing it for 5 seconds accesses change set point.

During configuration, it accesses the level shown on the display or, when setting a parameter, it accepts the new value.

*Short press: Less than 5 seconds.

4.2- Messages

	Flashing 0: Access code (Password) request You must enter the access code configured on L5 to execute the requested function (p. 16). VSee also parameter P2 (p. 21)
	Probe 1 or 2 faulty (open circuit, crossover or temperature outside the probe limits; NTC : -50 To 99 °C).
	Indicates a defrost is underway. When the defrost process has finished, the message will continue to be displayed during the time defined in parameter d3 (see Chapter 7.2).
	Alternating with temperature: Maximum temperature in control probe alarm. Temperature set in A1 has been reached (p. 15).
	Alternating with temperature: Minimum temperature in control probe alarm. Temperature set in A2 has been reached (p. 15).
	Alternating with temperature: External alarm activated (by digital input) (p. 15).
	Alternating with temperature: Severe external alarm activated (by digital input) (p. 15)
	Alternating with temperature: Defrost alarm time-out. Displayed when a defrost ends after the maximum time elapsed as defined in parameter d1. (p. 15)
	Alternating with temperature: Door open alarm. Shown if the door remains open longer than specified in parameter A12 (p. 15)
	Alternating with temperature: The maximum pump down stop time has been exceeded (P15) (p. 15)
	Alternating with temperature: The maximum pump down start-up time has been exceeded (P14) (p. 16).
	It indicates that a component in the compressor's safety chain has triggered (compressor motor guard, thermistors or high pressure controller). (p. 16).

5.- Component location



ATTENTION: Make sure to turn of the equipment's power supply before handling it, as different areas may be energised.



IMPORTANT: The availability of the elements described depends on the panel model.

AKO-17632, AKO-17635, AKO-17520, AKO-17521

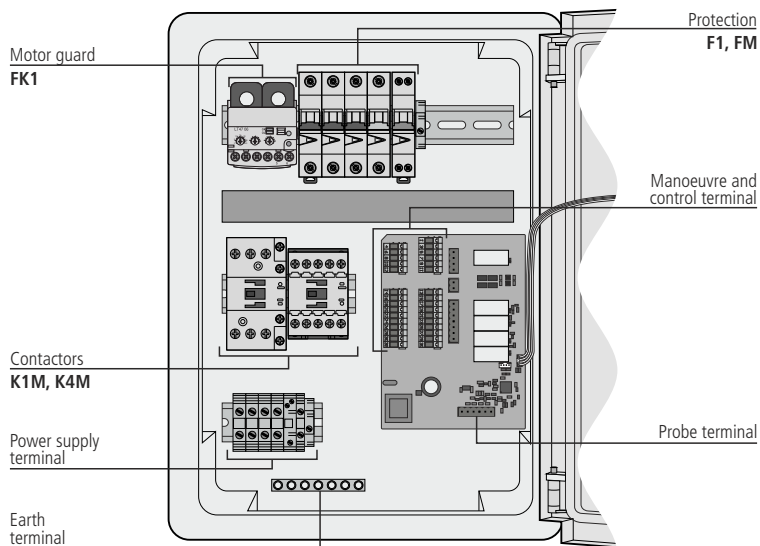

Identification

F1: General circuit-breaker

FM: Operation circuit breaker

FK1: Compressor motor guard + condenser fan 1 (depending on model)

K1M: Compressor contactor

K4M: Defrost contactor

AKO-17633, AKO-17634, AKO-17636, AKO-17637

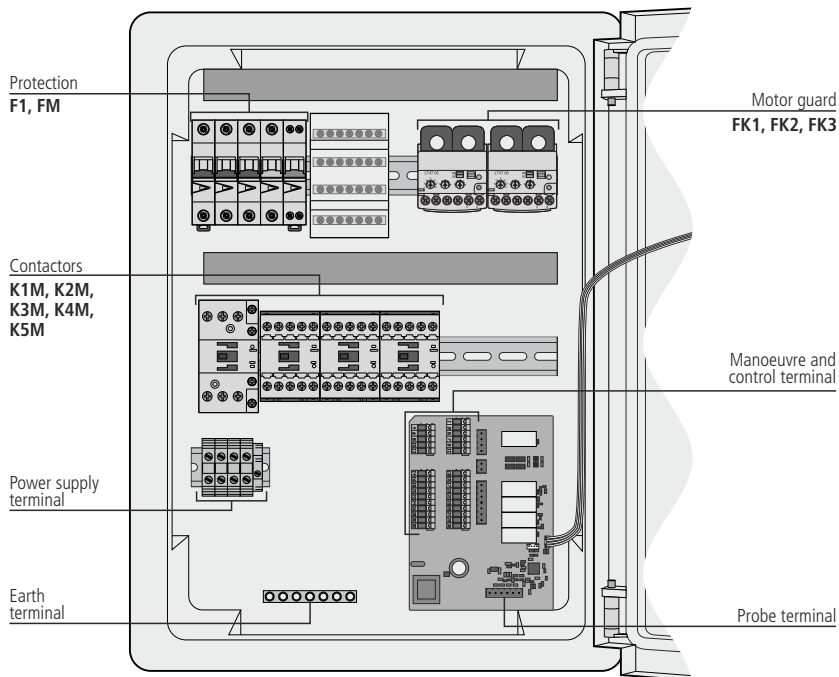

Identification

F1: General circuit-breaker

FM: Operation circuit breaker

FK1: Compressor motor guard + condenser fan 1 (depending on model)

FK2: Evaporator fan motor guard

FK3: Condenser fan motor guard 2

K1M: Compressor contactor

K2M: Evaporator fan contactor

K3M: Contactor for Condenser fan 2

K4M: Defrost contactor

K5M: Contactor for Condenser fan 1

6.- Quick configuration

The quick configuration menu allows the unit to be configured for the most common applications. Press the  key for 5 seconds to access it.

If the access code is activated, a 2 digit code is requested (See p. 16), if the code entered is not correct the unit will not enter programming.

If more specific configuration is required use the advanced configuration menu (see p. 18)

After 20 seconds without touching any key, the unit returns to the previous level without saving changes or it will exit programming.

Function of the keys in programming



Passes on to the next parameter or increases the value of the parameter.



Passes back to the previous parameter or decreases the value of the parameter.

SET

Accesses the selected parameter or accepts the value.

ESC

Allows exiting a parameter without saving the changes or exiting programming.

SP: Set point

It sets the coldroom's working temperature (see p. 10)

- Minimum: -45.0 *
- Maximum: 99 *

*(Depends on the bottom/top locking of the set point).

d0: Defrost frequency

Time that must elapse between the starting of each defrost (see p. 12)

d1: Maximum defrost duration

The defrost will end after this time has elapsed since it started.

F3: Fan status during defrost

It defines the status of the fans during defrost. **0**= Stopped **1**= Running

A1: Maximum alarm probe 1

Defines the temperature at which the maximum alarm will be triggered. Only affects probe 1.

- Minimum: -45.0 *
- Maximum: 99 *

*(Depends on the bottom/top locking of the set point).

A2: Minimum alarm probe 1

Defines the temperature at which the minimum alarm will be triggered. Only affects probe 1.

- Minimum: -45.0 *
- Maximum: 99 *

*(Depends on the bottom/top locking of the set point).

P26: Stoppage owing to pump down

It defines whether this function is active

- **0**= Without pump down
- **1**= With pump down

(see p. 14)

7.- Operation

7.1.- Compressor control

NORMAL OPERATION

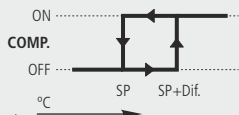

When the temperature in probe 1 reaches the set point value (**SP**) plus the differential of the probe (**C1**), the compressor and solenoid are activated and the temperature drops. When the set point value (**SP**) is reached, the compressor and solenoid stop.



If Pump Down is deactivated ($P26=0$), the compressor and the solenoid behave in the same way.

If Pump Down is activated ($P26=1$), the compressor and the solenoid behave as defined in section 7.5.

“CHANGE OF SET POINT” FUNCTION

It modifies the refrigerated facility's set point value.

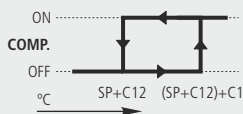

Operation is the same as in the normal mode, but increasing the set point the amount of degrees defined in the **C12** parameter.

It can be activated after a certain time has elapsed (defined in parameter **C11**) without activity in the cold room door, to do this one of the digital inputs such as “door contact” (**P10** or **P11** = **1**) must be configured.

Optionally, you can activate and deactivate this mode at will, using an external switch, configuring one of the digital inputs as “Change set point” (**P10** or **P11** = **4**).

If we set the **C11** parameter to 0, it can only be activated by external switch.

COMPRESSOR PROTECTION DELAY

There are three types of delay, selectable by parameter **C4**, to protect the compressor. These delays prevent continuous compressor starts and stops due to sudden changes in temperature.

OFF-ON (C4=0): Minimum compressor OFF time before each start-up.

OFF-ON / ON-OFF (C4=1): Minimum time during which the compressor will remain ON and OFF in every cycle. The delay time is defined by parameter **C5**.

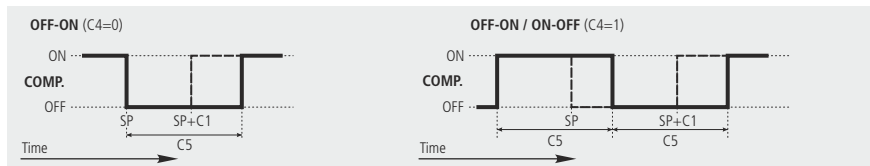

OPERATION IN CASE OF PROBE 1 FAILURE

In the event of probe 1 failure (fault, disconnection, etc.) compressor performance will depend on **C6** settings. Users may choose between 3 options:

C6=0: The compressor will be stopped until probe 1 is working again.

C6=1: The compressor will be operational until probe 1 is working again.

C6=2: The compressor will operate according to the average performance of the last 24 hours, taking into account the number of starts and stops and the average time in each state (stop-start).

C6=3: The compressor will run as scheduled in **C7** (ON) and **C8** (OFF).

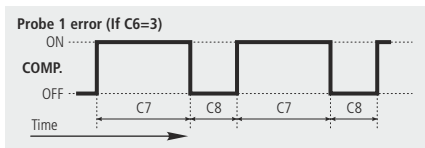

SET POINT LOCKING

Using the **C2** and **C3** parameters, it is possible to set an upper and a lower limit for the Set point (**SP**), which precludes configuring a set point that is too low or too high that could damage the installation or the stored product.

STOP FANS AND COMPRESSOR WHEN THE DOOR IS OPENED

The **P23** parameter defines whether the compressor and the evaporator fans stop when the cold room door is opened. To do so one of the digital inputs must be configured as "door contact" (**P10** or **P11=1**) (See page 22).

If the door stays open longer than the value programmed in the **P24** parameter, the compressor and the fans will return to their normal operation.

7.2.- Defrost control

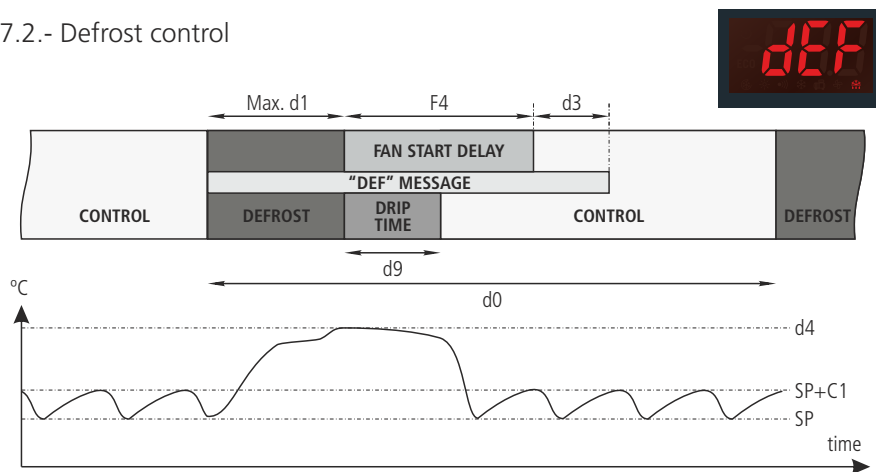
**Defrost start-up**

Defrost is initiated if:

- Time scheduled in parameter **d0** has passed since the beginning of last defrost.
- The ▲ key is pressed for 5 seconds.

Defrost type

By resistors: The defrost resistors start up and the compressor stops; defrost is the result of heat from the resistors. Fans will be running or not depending on parameter **F3**.

Drip time

Parameter **d9** sets drip time and the time added at the end of defrost cycle to allow for drainage of the remaining water in the evaporator. During this time the compressor and fans will not be running (unless defrost is by air).

Defrost termination

The defrost will terminate if:

- The temperature programmed in parameter **d4** has been reached in probe 2 Probe 2 must be activated (P4). In the event of probe 2 failure, defrosting will be complete once the maximum time has elapsed (**d1**)
- Time set in parameter **d1** has passed (maximum duration of defrost).
- The ❄ key is pressed for 5 seconds.

Message displayed during defrost

Set by parameter **d2**, with the choice of showing the actual temperature detected by probe 1 (**d2=0**), displaying the temperature detected by probe 1 at the start of defrost (**d2=1**) or displaying the DEF message (**d2=2**). The **d3** parameter defines the time during which the message is displayed, once the drip time (**d9**) and the fan stop time (**F4**) is over.

Other parameters

Parameter **d5** allows users to specify if the unit will (**d5=1**) or will not (**d5=0**) defrost when powered up (initial start-up or after a power failure). In case of choosing option YES (**d5=1**), the defrost will start after the delay time specified in **d6**.

Using parameter **d8**, users define the computation of time in **d0**, choosing between total time elapsed (**d8=0**) or the total compressor running time (**d8=1**).



NOTE: If parameter **d1** is set to 0, no defrost will be performed.

Remote defrost

This function allows activating the defrost of the unit using an external button, connecting it to one of the digital inputs that must be configured as "remote defrost" (**P10 6 P11=6**).

7.3.- Fan control

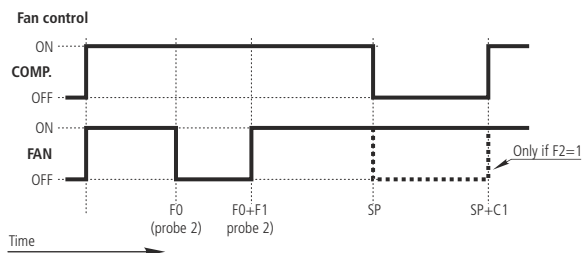

Fans are controlled with probe 2 (evaporator) and parameters **F0** (shutdown temperature) and **F1** (Probe differential).

Even if probe 2 is not connected or an error is detected in the probe (E2), the fans will always run regardless of parameters **F0** and **F1**, but taking into account parameters **F2** to **F5**.

Parameter **F2** defines the status of the fans during compressor stops.

Parameter **F3** defines the status of fans during defrost.

Parameter **F4** defines the fan start-up delay after defrost (see section 7.2)

7.4.- Condenser fan control

Condenser fan 1 is activated and deactivated at the same time as the compressor.

Condenser fan 2 can be controlled by a high pressure switch.

They have no associated parameter.



7.5.- Pump down function

This function prevents compressor problems caused by movement of the refrigerant, using a stop/start technique of the unit controlled by liquid solenoid, the low pressure switch and the compressor.

For this function to be active, it must be configured in parameter **P26= 1**.

PARO

When the temperature in probe 1 reaches the set point (**SP**) value, the liquid solenoid closes.

Since the compressor is still running the evaporator pressure drops suddenly. When it reaches a specific point, the low pressure switch is activated, changing the state of digital input 1, and the controller stops the compressor.

This manoeuvre isolates the refrigerant from the compressor crankcase, preventing serious damage on start-up.

In case of low pressure switch failure, the controller stops the compressor after the safety time set at **P15**, showing the message "Pd", but it will continue to function normally. (informative message, does not affect the equipment operation).

If time **P15** is 0 (default value), the compressor will not stop until the low pressostat is activated, but it will display the "Pd" message after 15 minutes.

STARTUP

When the temperature in probe 1 reaches the set point plus the differential (**SP + C1**) value, the liquid solenoid opens. This increases the pressure in the evaporator, deactivating the low pressure switch, which turns the compressor on.

If a period of time (determined by **P14**) has elapsed after the liquid solenoid is opened, the low pressure switch will not be deactivated, the controller will once again close the solenoid, and the "LP" message will be displayed. This manoeuvre will be repeated every 2 minutes, indefinitely, until the pressure switch is deactivated and the installation reverts to its normal operation.

If the time for **P14** is 0 (default value), the solenoid will stay open until the low pressure switch is deactivated, but after 3 minutes it will display the "LP" message.

STAND-BY

If the pump-down function is active, some time may elapse from the time the stand-by function starts until the controller stops. This is because certain control phases of the system cannot be stopped.

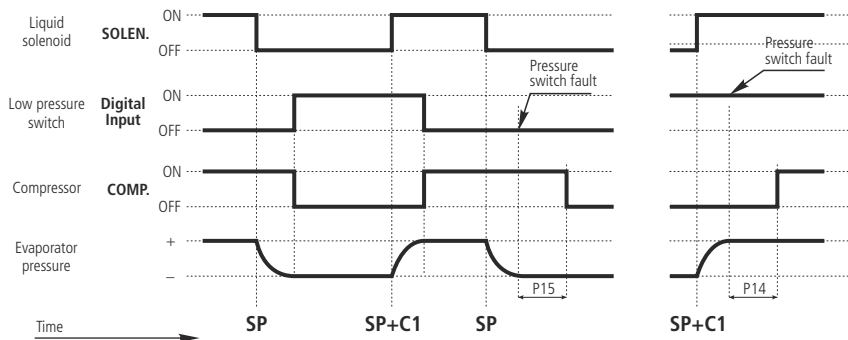

7.6.- Alarms

The unit warns the user by displaying an on-screen message when the programmed criteria are met.

Max/Min Temperature Alarm

Shows the **AH** or **AL** message when the temperature in probe 1 reaches the value set in the **A1** (maximum temperature) or **A2** (low temperature) parameters.

This value can be:

Absolute (A0=1): **A1/A2** should indicate the temperature at which the alarm should be activated.

Relative to SP (A0=0): **A1/A2** should indicate the number of degrees above or below the set point at which the alarm is activated. This option allows users to adjust the set point without having to modify the high and low alarm settings.

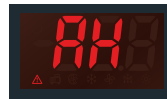

Parameter **A10** sets the differentials for both parameters (hysteresis).



Example

In a controller we configure the following parameters: **SP=2**, **A1=10**, **A10=2**

- If **A0=0** (relative to SP), the maximum temperature alarm goes off when probe 1 reaches 12 degrees and is disabled when it reaches 10 degrees.
- If **A0=1** (absolute), the maximum temperature alarm goes off when probe 1 reaches 10 degrees and is disabled when it reaches 8 degrees.



In the case of configuring the alarms in relation to the **SP (A0=0)**, the value set for the **SP** parameter is taken as a reference, even though the "CHANGE SET POINT" function may have been activated.

External alarm/severe external alarm

Displays the message **AE** (external alarm) or **AES** (severe external alarm), when the digital input configured as external alarm or severe external alarm is activated.

The severe external alarm also deactivates all the charges, therefore, the temperature regulation is stopped. When this alarm disappears the device returns to its normal operation.

At least one of the digital inputs must be configured as external alarm (**P10** or **P11=2**) or severe external alarm (**P10** or **P11=3**).



Defrost alarm completed by time.

Shows the **Adt** alarm message when a defrost terminates by time-out, if parameter **A8=1**.

Door open alarm

Displays the **PAb** message when the door stays open for a time greater than that set with parameter **A12**. (One of the digital inputs must be configured as door contact (**P10** or **P11=1**).

Pump down malfunction error (Stop)

Displays the **Pd** message if a malfunction is detected when the installation is stopped using the pump down manoeuvre. (See p. 14).



Pump down malfunction error (Start up)

Displays the **LP** message if a malfunction is detected when the installation is started up using the pump down manoeuvre. (See page 14).

**Compressor safety chain alarm**

The ASC message is displayed if any component in the compressor's safety chain is triggered (compressor motor guard, thermistors or high pressure controller). Regulation is stopped until protection has been restored.

**Alarm delay**

These delays prevent the display of specific alarms while allowing the unit to recover normal operation after certain events.

- Start-up delays (**A3**): Delays activation of temperature alarms on power-up (start-up or after a power failure). This allows avoiding continuous alarms upon start-up
- Delay after defrost (**A4**): Delays activation of temperature alarms post-defrost.
- Delay of max/min temperature alarm (**A5**): Delays activation of maximum (**A1**) and minimum (**A2**) temperature alarms from the moment temperature probe 1 reaches the set value.
- Delay of external alarm activation (**A6**): Delays the activation of the external alarm from the moment the digital input becomes active.
- Delay of external alarm deactivation (**A7**): Delays the deactivation of the external alarm from the moment the digital input becomes inactive.
- Door opening alarm relay (**A12**): Delays activation of the open door opening detection alarm.

7.7.- Access code (password)

It allows protecting the configuration of the unit using a 2 digit code (from 01 to 99). If it is active a code is requested when you try to access the programming menu. This menu cannot be accessed if a wrong value is entered. The code is defined using the **L5** parameter.

Parameter **P2** defines the operation of this code.

8.- Parameter transfer

This function allows transferring the programmed parameters from one device to others, using the **AKO-D14918** programming key. This will save a lot of time when configuring similar devices.

Transfer parameters from the equipment to the key

- Connect the programming key in the parameter server connector.
- Press the **READ** key on the programming key.
- Disconnect the device programming key.

Transfer parameters from the key to the equipment

- Connect the programming key in the parameter server connector.
- Press the **RECORD** key for the programming key.
- Disconnect the device programming key.

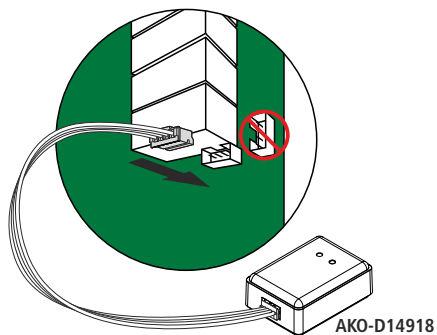
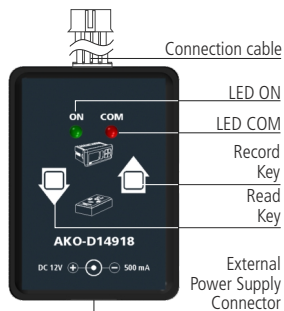

9.- Advanced configuration

Using the advanced configuration menu, you can set **ALL** the equipment's parameters.

The parameters are grouped into 6 sections depending on their function. To access it, press the  key for 10 seconds.

If the access code is activated, a 2 digit code is requested (See page 16), if the code entered is incorrect the unit will not enter programming mode.

To see the complete parameters list, refer to page 19.

After 20 seconds with no key being pressed, the equipment will return to the previous level. If you are on level 3, the changes will not be saved.

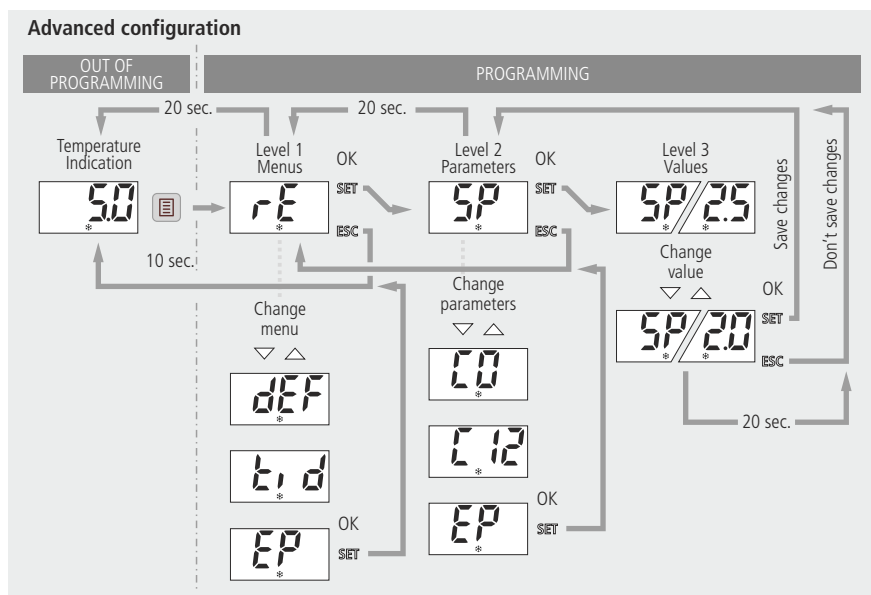

9.1.- Return to initial parameters

This function configures all the unit's parameters to its default values, i.e., as it leaves the factory.

In order to return the computer to its initial settings, go to the programming menu and set parameter **P3** to 1. The computer will now restart with its factory settings.



WARNING: Any change made in the unit's configuration will be lost.

9.2.- Program version

The **PU** and **Pr** settings allow the version and review of the firmware installed in the equipment to be displayed. Use this information if you have to ask for advice from the technical assistance service.

9.3.- Parameters

The parameters are grouped into 6 sections depending on their function. To access it, press the  key for 10 seconds.

The **Def.** column shows factory-set default parameters.

Temperature values are expressed in °C. (Equivalent temperature in °F)

Level 1.- REGULATION AND CONTROL



Level 2	Description	Units	Min	Def	Max.
SP	Temperature Adjustment (Set Point) (Pág. 10)	(°C/°F)	-45	0.0	99
C0	Calibrating probe 1 (Offset)	(°C/°F)	-20.0	0.0	20.0
C1	Probe 1 differential (Hysteresis) (Histéresis) (Pág. 10)	(°C/°F)	0.1	2.0	20.0
C2	Upper blocking of the set point (Page 11) (cannot be set above this value)	(°C/°F)	C3	99	99
C3	Lower blocking of the set point (Page 11) (cannot be set below this value)	(°C/°F)	-45	-45	C2
C4	Type of delay for protection of the compressor (Page 11) 0 =OFF/ON (since the last disconnection); 1 =OFF-ON/ON-OFF (since the last shut-down /start-up)		0	0	1
C5	Protection delay time (value of the option selected in parameter C4) (Page 11)	(min.)	0	0	120
C6	Status of COOL relay with probe fault (Page 11): 0 =OFF; 1 =ON; 2 =Average based on last 24 hours prior to probe fault; 3 =ON-OFF as prog. C7 and C8		0	2	3
C7	Time relay ON in case of faulty probe (Page 11): (If C7=0 and C8≠0, the relay will always be OFF deenergised)	(min.)	0	10	120
C8	Time relay OFF in case of fault of probe 1 (Page 11): (If C8=0 y C7≠0, the relay will always be ON energised)	(min.)	0	5	120
C11	Idle time of the digital input for the change Set Point function to be activated (Only if P10 or P11 =1) (0 =OFF) (Page 10)	(h.)	0	0	24
C12	Variation of the set point (SP) when the change set point function is active. (SP+C12 ≤ C2) (0 = disabled) (Page 10)	(°C/°F)	C3-SP	0,0	C2-SP
EP	Exit to Level 1				

Level 1.- DEFROST CONTROL



Level 2

	Description	Units	Min	Def	Max.
d0	Defrost frequency (Time between two starts) (Page 12)	(h.)	0	6	96
d1	Maximum defrost duration (0=defrost deactivated) (Page 12)	(min.)	0	15	255
d2	Type of message during defrost: (Page 12) 0=Current temperature; 1=Temperature at start of defrost; 2=Display dEF message		0	2	2
d3	Maximum duration of message (Time added at the end of the defrost process) (Page 12)	(min.)	0	5	255
d4	Defrost end temperature (probe 2) (If P4 ≠ 1) (Page. 12)	(°C/°F)	-45	8.0	99,0
d5	Defrost on equipment start-up (Page 13) 0=NO, First defrost as per d0 1=YES, First defrost as per d6		0	0	1
d6	Defrost start delay on equipment start-up (Page 13)	(min.)	0	0	255
d8	Calculated time between defrost period (Page 13): 0=Total actual time; 1=Sum of times the compressor is on		0	0	1
d9	Drip time at end of defrost (Page 12) (compressor and fans off) (if P4 ≠ 1)	(min.)	0	1	255
EP	Exit Level 1				

Level 1.- FAN CONTROL



Level 2

	Description	Units	Min	Def	Max.
F0	Fan shut-down temperature as per probe 2 (if P4 ≠ 1) (Page 13)	(°C/°F)	-45	45	99,0
F1	Probe 2 differential (If P4 ≠ 1) (Page 13)	(°C/°F)	0,1	2,0	20,0
F2	Stop fans when stopping compressor 0=No, 1=Yes (Page 13)		0	1	1
F3	Fan status during defrost: (Page 13) 0=Stopped; 1=Running		0	0	1
F4	Starting delay after defrost (if F3=0) (Page 13) Will only operate if it is higher than d9	(min.)	0	3	99
EP	Exit Level 1				

Level 1.- ALARM CONTROL



Level 2	Description	Units	Min	Def	Max.
A0	Configuration of temperature alarms (Page 15): 0 =Relative to SP 1 =Absolute		0	1	1
A1	Maximum alarm probe 1 (must be greater than SP) (Page 15)	(°C/°F)	A2	99,0	99,0
A2	Minimum alarm probe 1 (must be greater than SP) (Page 15)	(min.)	-45	-45	A1
A3	Temperature alarm delay during start-up (Page 16)	(min.)	0	0	120
A4	Temperature alarm delay after completion of a defrost (Page 16)	(min.)	0	0	99
A5	Temperature alarm delay after reaching the value of A1 or A2 (Page 16)	(min.)	0	30	99
A6	External alarm delay when receiving digital input signal (P10 or P11=2 or 3) (Page 16)	(min.)	0	0	120
A7	Deactivation delay of the external alarm when the signal of the digital input disappears (P10 or P11=2 or 3) (Page 16)	(min.)	0	0	120
A8	Show warning if defrost is terminated by time-out 0 =No, 1 =Yes (Page 15)		0	0	1
A10	Temperature Alarm Differential (A1 and A2) (Page 15)	(°C/°F)	0,1	1,0	20,0
A12	Door open alarm delay (if P10 or P11=1) (Page 15)	(min.)	0	10	120
EP	Exit Level 1				

Level 1.- GENERAL STATUS



Level 2	Description	Units	Min	Def	Max.
P1	Delay of all functions on receiving electrical power	(min.)	0	0	255
P2	Función del código de acceso (password) (Pág. 16) 0 = Inactivo; 1 = Bloqueo acceso a parámetros; 2 = Bloqueo del teclado		0	0	2
P3	Configures the default factory settings 0 = No changes 1 =Return to default settings		0	0	1
P4	Selection of type of inputs 1 =Probe S1 2 =Probes S1 + S2		1	1	2
P7	Temperature display mode 0 =Integers in °C 1 =One decimal in °C 2 =Integers in °F 3 =One decimal in °F		0	1	3
P8	Probe to be displayed (as per parameter P4) 0 =visualization of all the probes in sequence; 1 =Probe S1 2 =Probe S2		0	1	2

Level 2

	Description	Units	Min	Def	Max.
P10	Configuring digital input 1 0= Off 1= Door contact 2= External alarm 3= Severe external alarm 4= Change Set Point 5=Remote defrost		0	0	5
P11	Configuring digital input 2 0= Off 1= Door contact 2= External alarm 3= Severe external alarm 4= Change Set Point 5=Remote defrost		0	0	5
P12	Digital input polarity 1 0=Energised on closed contact, 1=Energised on open contact		0	1	1
P13	Digital input polarity 2 0=Energised on closed contact, 1=Energised on open contact		0	1	1
P14	Maximum start-up time after pump down (Page 14) (Values between 1 and 9 seconds are not accepted) (0=Disabled)	(sec.)	0	0	120
P15	Maximum pump down time (Page 14) (0=Disabled)	(min.)	0	0	15
P23	Stop evaporator fans and compressor on opening door (Page 11) 0=No 1=Yes		0	0	1
P24	Start up delay for fans and compressor with door open (Page 11)	(min.)	0	0	999
P26	Pump Down 0=Without pump down 1=With pump down (Page 9)		0	1	1
EP	Exit Level 1				

Level 1.- ACCESS CONTROL AND INFORMATION (tid)



Level 2

	Description	Units	Min	Def	Max.
L5	Access code (Password) (Page. 16)		0	0	99
PU	Control board software version (Information)			-	
Pr	Control board software review (Information)			-	
PUd	Display board software (Information)			-	
Prd	Display board software review (Information)			-	
EP	Exit Level 1				

10.- Technical specifications

Rated voltage Un	400V~ ±10 % 50/60 Hz ±5 %
Rated voltage Ue	230V~ ±10 % 50/60 Hz ±5 %
Maximum nominal input current	32A
Short-circuit current at the connection point	6 kV
Probe temperature range	-45.0 °C to 99.9 °C
Resolution, setting and differential	0.1 °C
Thermometric precision	± 1 °C
Precision of the NTC probe at 25 °C	± 0.4 °C
Input for NTC probe	AKO-14901
Maximum input power in the operation	30 VA
Working ambient temperature	-5 °C to 40 °C
Storage ambient temperature	-30 °C to 70 °C
Overvoltage category	II s/ EN 61439-1
Degree of pollution	II s/ EN 61439-1
Degree of protection	IP65
Dimensions	AKO-17632 / 17635 / 15720 / 15721 400(An) x 300(AI) x 165(P) mm
	AKO-17633 / 17634 / 17636 / 17637 500(An) x 400(AI) x 175(P) mm
Double isolation between power supply, secondary circuit and relay output.	
Type of assembly	Fixed internal
Programming key compatible	AKO-D14918
Encapsulated assembly	

AKO ELECTROMECÁNICA, S.A.L.
Avda. Roquetes, 30-38
08812 • Sant Pere de Ribes.
Barcelona • Spain.

Tel.: +34 902 333 145
Fax: +34 938 934 054
www.ako.com

Nos reservamos el derecho de suministrar materiales que pudieran diferir levemente de los descritos en nuestras Hojas Técnicas. Información actualizada en nuestra web.